

客户图

REV	LTR	DESCRIPTION	DATE	APPROVED
A0		依新料号编码原则发行图面	20101118	SEEK
A1		根據實物更改插腳位尺寸	20111201	XU RU PEI

NOTES:

1. MATERIAL SPECIFICATION:

- 1) HOUSING MATERIAL: WHITE (UL94V-0);
- 2) SHELL MATERIAL: SPCC T=0.30  
PLATING: NICKEL;
- 3) TERMINAL: C5191 T=0.25  
PLATING: SEMI GOLD TIN G/F;

2. ELECTRICAL CHARACTERISTIC:

- 1) INSULATION RESISTANCE: 1000M  $\Omega$  MIN;
- 2) CONTACT RESISTANCE: 30m  $\Omega$  MAX;
- 3) WITHSTANDING VOLTAGE: 500V AC;

3. MECHANICAL CHARACTERISTICS:

- 1) INSERTION FORCE: 3.57Kgf Max;
- 2) EXTRACTION FORCE: 1.02Kgf Min;

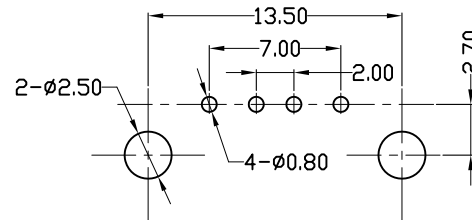
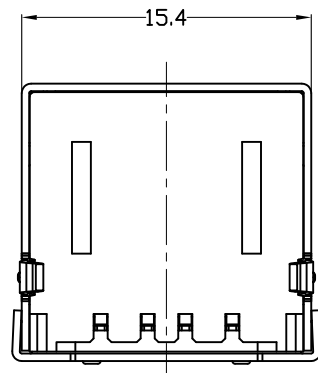
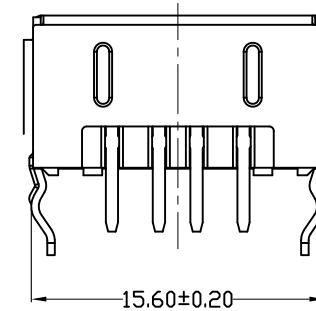
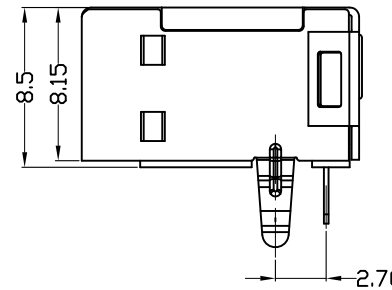
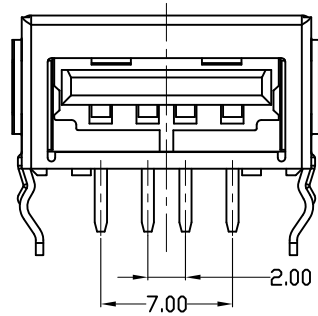
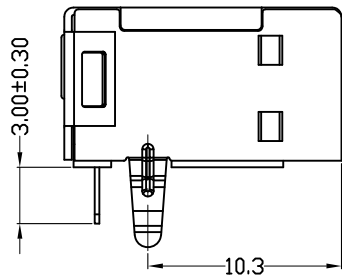
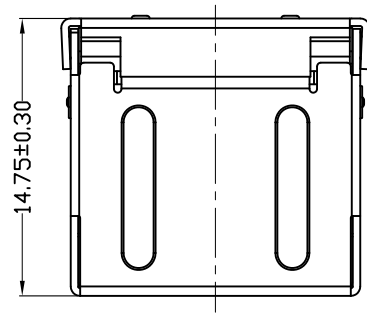

PCB LAYOUT

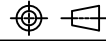
TOLERANCES						
.X	±0.30					
.XX	±0.20	TITLE: USB A/F DIP 90° 单层全包				
.XXX	±0.10	DRAWING NO.:				
ANGLES ±2.00°		DRAWN:				
		REV.:	SIZE:	UNIT:	SCALE:	SHEET:
APPD.:		A/1	A4	M M	1 : 1	1 / 1
CHECK:						